



EUROCAVE

PROFESSIONAL

WB 8.0



Range	Wine Bar
Function	2 serving temperature Service
Capacity*	8 preserved bottles + 6 storage bottles

GENERAL FEATURES

Overall size 602 x 1076 x 480 mm (HxWxD)
Weight 85 kg
Cooling agent R600a

Warranty

2 years

PRODUCT CHARACTERISTICS

FUNCTIONALITIES

- **Electronic regulation from 6 to 18°C/ 43-64°F**
 - 6°-15°C/43-59°F for white wines
 - 12-18°C/54-64°F for red wines
- **Interior display**
- Both temperature settings from the right compartment
- Red or with wine whatever the compartment

COLD TECHNOLOGY AND INSULATION

Production of cold air	Ventilated cold air Compressor
Production of warm air	Heater
Heat activation	Automatic
Leads	CE/US/UK/JA/C6/ CH/CN/AU
Type of walls	ABS
Type of external covering	Black metal
Type of insulation	Polystyrene foam with UV protection
Type of glass	

FITTINGS & ACCESSORIES

- 2 full glass doors, with double safety lock
- Interior lighting with multicolour LED (remote control)
- Frequency detector
- 2 adjustable feet
- Thermal insulation and U.V. protection.
- Individual wine preservation (new system)
- Air extraction fault warning indicators
- Excess condensation water collected in 2 drawers
- Black tempered glass top



ENERGY CONSUMPTION & PERFORMANCE

Consumption per 24hrs** (KWh)	1
Ambient temperature operating limit	10 to 35°C (50-95°F)
Electrical power (at 25°C)	75 W

WINE { BAR 8.0

Can be flush-fitted
(see requirements to be met)

<http://www.finewines.com.sg/>

* Traditional Bordeaux bottles
 ** with an ambient temperature of 25°C

Flush-fitting diagram

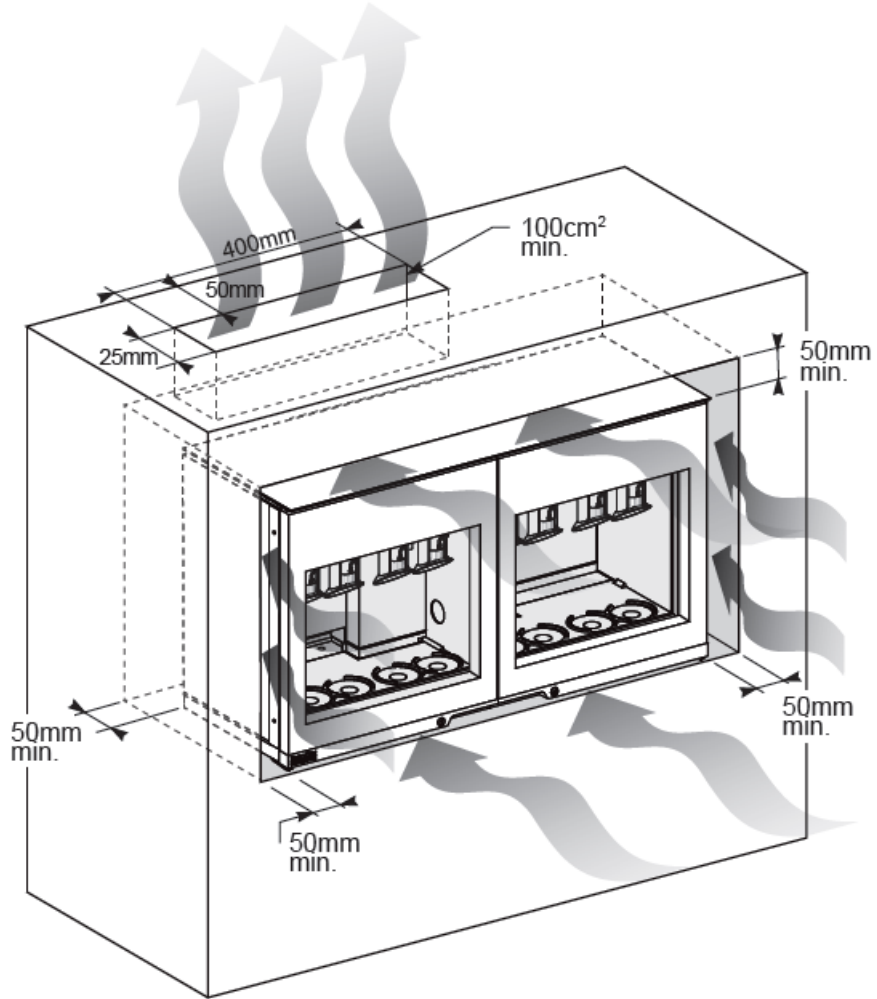

View from above

